

Assembly Instructions

Before you begin, please make sure all parts and proper quantities are included. (See Part Identifier Key) Any parts damaged during shipment must be reported within 24 hours of receipt. To report information regarding damages or if you have any questions, please call 800.242.2303.

Step 1:

- Place the TORO top face down on a protected flat surface.

Step 2:

- Place TORO frame down on top of the TORO top and align with pre-drilled pilot holes.
- If assembling an **Epoxy top**, see Epoxy TORO Table Assembly Instructions.
- If assembling a **2 piece Hardwood top**, see Hardwood TORO Table Assembly Instructions.

Step 3:

- Using a # S2 square bit, secure frame to table top with #10 x 3/4" square pan screws. One screw per tab.

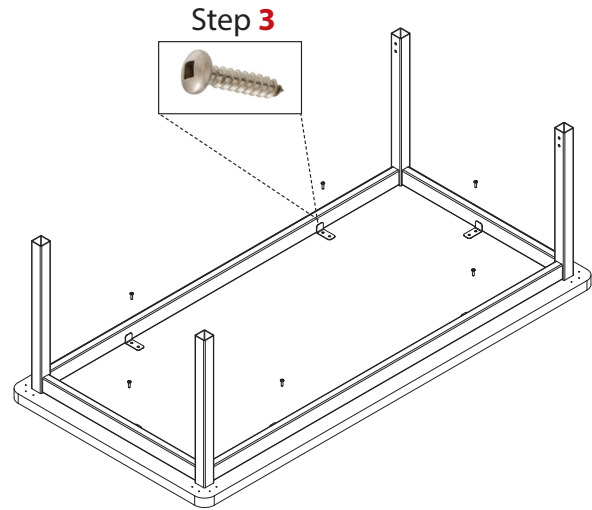

Step 4:

- Locate TORO inserts. Remove M6 screws and #12 star washers from the insert using a 4mm hex wrench.

Step 5:

- Place insert into TORO frame and once desired height is attained, place #12 star washer and M6 screw through the hole and tighten with a 4mm hex wrench. Repeat with the 2nd star washer and M6 screw.
- Repeat Step 5 for the remaining inserts.

Step 6:

- With someone's help, turn table upright.

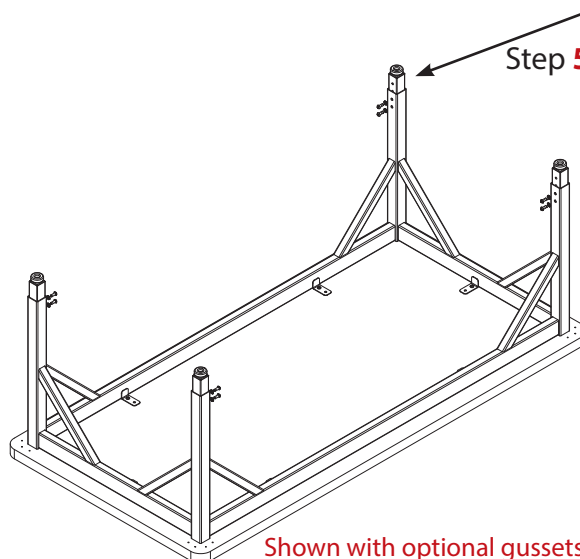
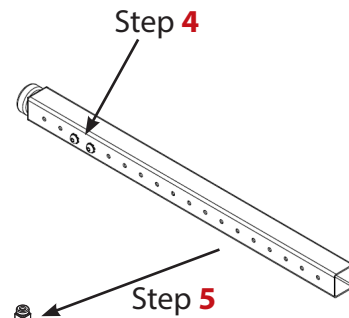

Tools Required

- 4mm Hex Wrench
- Screw Gun
- # S2 Square Bit

Part Identifier Key

Part #	Description	Qty.	
0408231	#10 x 3/4" Square pan screws <i>(Used to attach frame to top)</i>	10 (Included in Hardware Pack located in leg box. May need less depending on size and work service)	

3" Heavy Duty Caster Hardware Pack (04066968) Used only with 2" adj. legs (-ALR)

Part #	Description	Qty.	
04067460	1/4" Star washers	4 per set	
04067064	M6 1x18 screws <i>(Used in leg insert to prevent bending of the leg insert)</i>	4 per set (Included in Hardware Pack located in leg box as standard. Discard if casters are not installed.)	

3" Heavy Duty Caster Hardware Pack (0402020) Used only with 1.5" adj. legs (-ADJ)

04067460	1/4" Star washers	4 per set	
0401259	M6 1x14 screws <i>(Used in leg insert to prevent bending of the leg insert)</i>	4 per set (Included in Hardware Pack located in leg box as standard. Discard if casters are not installed.)	

TORO Leg Options

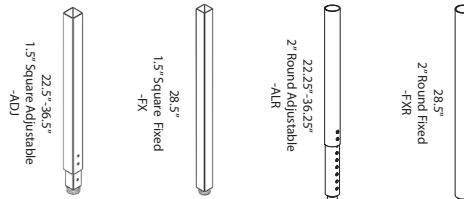

Assembly Instructions

Before you begin, please make sure all parts and proper quantities are included. (See Part Identifier Key) Any parts damaged during shipment must be reported within 24 hours of receipt. To report information regarding damages or if you have any questions, please call 800.242.2303.

Step 1:

- Remove Nylon glide from leg by rotating counterclockwise until glide is free.

Step 2:

- Place stem of optional footing into the hole on the leg. Rotate clockwise until fully inserted into leg.
- Casters are **NOT** to be used as a leveling device.

Step 3:

- Tighten with a 14mm open-ended wrench. (only with the Dual wheel soft tread locking caster.)

Step 4:

- Repeat for each caster or glide.

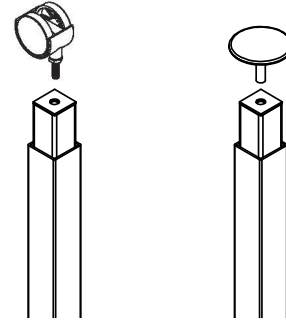





Installing casters on tables with epoxy resin tops will void the Epoxy warranty.

Tools Required

- 14mm open-ended wrench

Part Identifier Key

Part #	Description	Qty.	
040164	1 3/8" Dia. Grand Hank glide, 3/8"-16 x 1"	1 per leg	
04067920	1.5" Soft Touch glide	1 per leg	
33056S	1.25" Steel glide	1 per leg	
04067540	Dual wheel soft tread locking casters (N/A on epoxy resin tops)	1 per leg	

TORO Leg Options

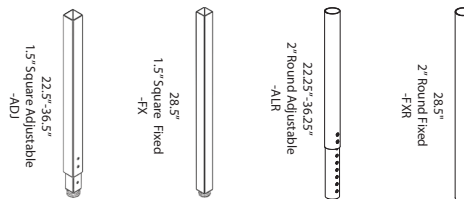

Assembly Instructions

Before you begin, please make sure all parts and proper quantities are included. (See Part Identifier Key) Any parts damaged during shipment must be reported within 24 hours of receipt. To report information regarding damages or if you have any questions, please call 800.242.2303.

Step 1:

- Before placing caster in the bottom of the leg, lock the caster by pushing down on the brake lever.

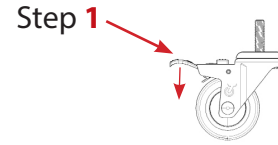

Step 2:

- Twist the stem of the caster into the hole on the bottom of the leg. Applying thread locking adhesive can help prevent unexpected loosening of the caster.

Step 3:

- Use 3/4" wrench to tighten 3/4" nut on stem of caster.

Step 4:

- If using adj. legs, insert star washer and M6 screw in hole closest to the caster and tighten with 4mm hex wrench. **DO NOT OVER TIGHTEN.**
- If using a **FIXED leg**, you will **NOT** need to use a star washer and M6 screw.

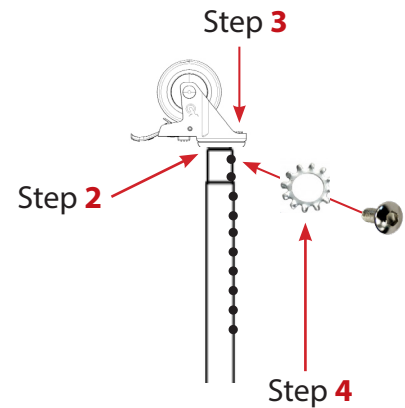

Step 5:

- Repeat for remaining casters.

Casters are **NOT** to be used as a leveling device.

Tools Required

- 3/4" Wrench
- 4mm Hex Wrench
- Thread Locking Adhesive (optional)

Installing casters on tables with epoxy resin tops will void the Epoxy warranty.

Part Identifier Key

Part #	Description	Qty.	
0400993	3" heavy duty locking casters	1 per leg	

3" Heavy Duty Caster Hardware Pack (04066968) Used only with 2" adj. legs (-ALR)

Part #	Description	Qty.	
04067460	1/4" Star washers	4 per set	 (Included in Hardware Pack located in leg box as standard. Discard if casters are not installed.)
04067064	M6 1x18 screws	4 per set	

3" Heavy Duty Caster Hardware Pack (0402020) Used only with 1.5" adj. legs (-ADJ)

Part #	Description	Qty.	
04067460	1/4" Star washers	4 per set	 (Included in Hardware Pack located in leg box as standard. Discard if casters are not installed.)
0401259	M6 1x14 screws	4 per set	

Assembly Instructions

Before you begin, please make sure all parts and proper quantities are included. (See Part Identifier Key) Any parts damaged during shipment must be reported within 24 hours of receipt. To report information regarding damages or if you have any questions, please call 800.242.2303.

Step 1:

- If assembling a Hardwood top that has a depth greater than 36", top will be in 2 pieces (.5" undersized on length). Place both top halves face down on a protected flat surface. Align together the dog bone holes on both tops.

Step 2:

- Adjust Tite joint fastener to the size of the field joint opening and then place the fastener into each opening. Using a $\frac{7}{16}$ " wrench, tighten each fastener so that both tops are securely clamped together.

Step 3:

- Place TORO frame down on top of the TORO top and align with pre-drilled pilot holes.

Step 4:

- Using a # S2 square bit, secure frame to table top with #10 x $\frac{3}{4}$ " Square pan screws. One screw per tab.

Step 5:

- Locate TORO inserts. Remove M6 screws and #12 Star washers from the insert using a 4mm hex wrench.

Step 6:

- Place insert into TORO frame and once desired height is attained, place #12 star washer and M6 screw through the hole and tighten with a 4mm hex wrench. Repeat with the 2nd Star washer and M6 screw.
- Repeat Step 6 for the remaining inserts.

Step 7:

- With someone's help, turn table upright.

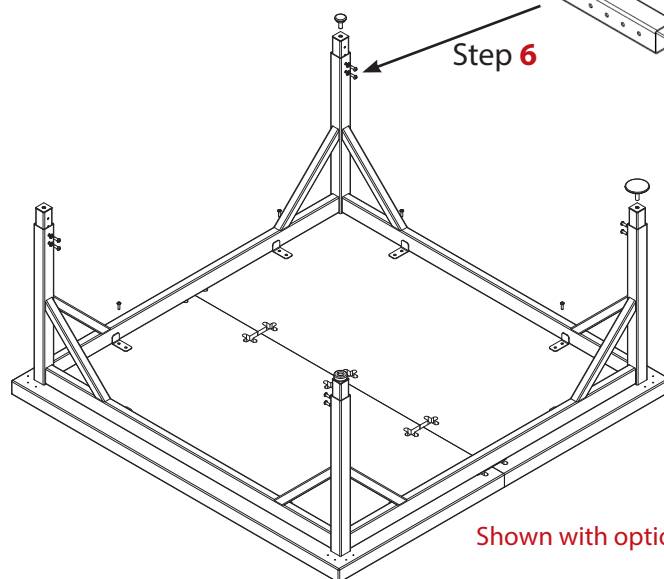
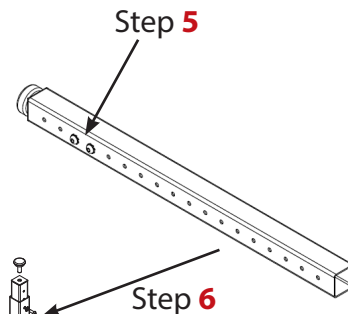
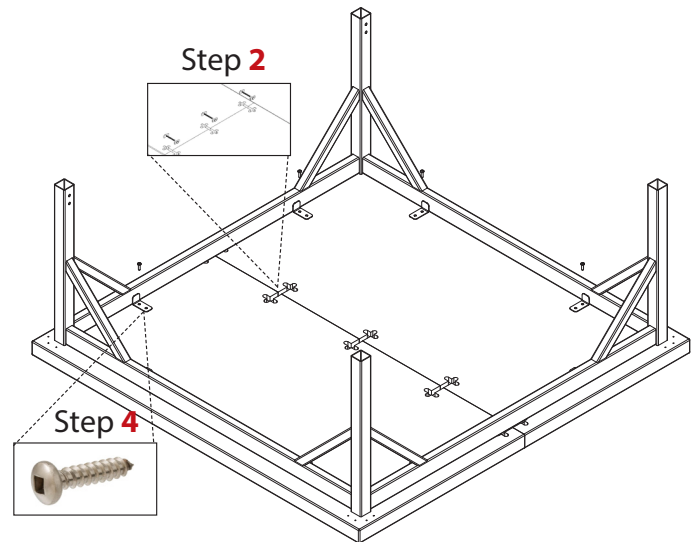



Shown with optional gussets

Tools Required

- $\frac{1}{2}$ " Wrench
- $\frac{7}{16}$ " Wrench
- Screw Gun
- # S2 Square Bit

Part Identifier Key

Part #	Description	Qty.	
0406902	Tite joint fasteners	# depends on top size	
0408231	#10 x 3/4" Square pan screws <i>(Used to attach frame to top)</i>	10 (Included in Hardware Pack located in leg box. May need less depending on size and work service)	

3" Heavy Duty Caster Hardware Pack (04066968) Used only with 2" adj. legs (-ALR)

Part #	Description	Qty.	
04067460	1/4" Star washers	4 per set	
04067064	M6 1x18 screws <i>(Used in leg insert to prevent bending of the leg insert)</i>	4 per set (Included in Hardware Pack located in leg box as standard. Discard if casters are not installed.)	

3" Heavy Duty Caster Hardware Pack (0402020) Used only with 1.5" adj. legs (-ADJ)

04067460	1/4" Star washers	4 per set	
0401259	M6 1x14 screws <i>(Used in leg insert to prevent bending of the leg insert)</i>	4 per set (Included in Hardware Pack located in leg box as standard. Discard if casters are not installed.)	

TORO Leg Options

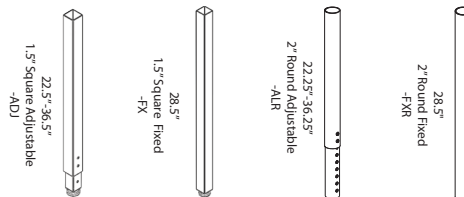

Assembly Instructions

Before you begin, please make sure all parts and proper quantities are included. (See Part Identifier Key) Any parts damaged during shipment must be reported within 24 hours of receipt. To report information regarding damages or if you have any questions, please call 800.242.2303.

Step 1:

- Place the TORO frame with legs on a protected flat surface.

Step 2:

- Locate TORO inserts. Remove M6 screws and #12 star washers from the insert using a 4mm hex wrench.

Step 3:

- Place insert into TORO frame and once desired height is attained, place #12 star washer and M6 screw through the hole and tighten with a 4mm hex wrench. Repeat with the 2nd star washer and M6 screw.
- Repeat Step 3 for the remaining inserts.

Step 4:

- Turn frame (with legs attached) upright.
- Place the TORO Epoxy **TOP** face down on a protected flat surface next to the completed TORO frame.

Step 5:

- Make sure frame and top are clean and free from any debris and/or contamination that would interfere with adhesion of sealant applied.
- In adhering the tops to the frames, we have found that using a polyurethane sealant/adhesive works best in this application. It is recommended to identify an adhesive sealant that when fully cured, it retains it's flexibility.

Step 6:

- Apply a bead of polyurethane sealant/adhesive (provided by installer) on the full perimeter of the frame and manually center top to the frame. (There will **NOT** be any pre-drilled pilot holes in the Epoxy top.)
- DO NOT attempt to use ANY hardware to attach the top to the frame which are included in the leg packaging.**
- Table must cure for **24 HOURS** in this position before continuing to Step 7.

Step 7:

- After letting assembled frame and top cure for 24 hours, turn table upright with someone's help.

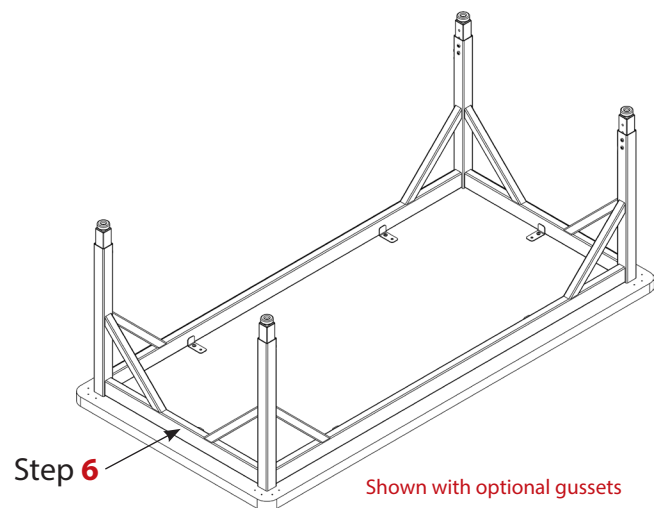
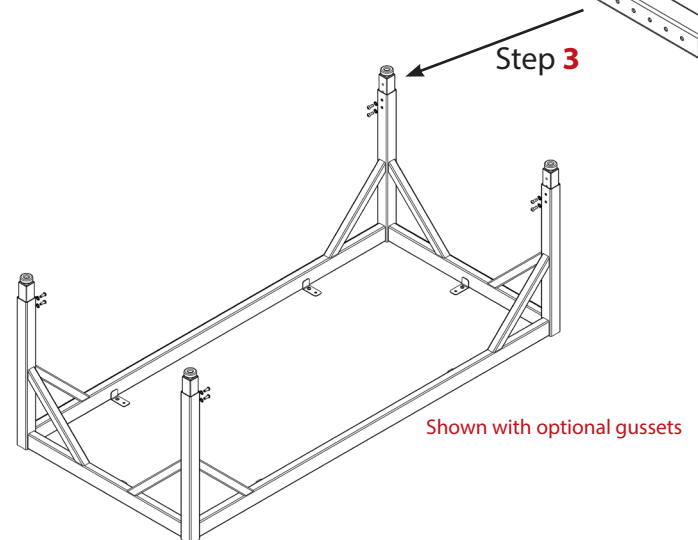
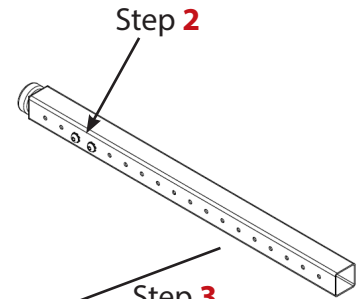

Tools Required

- 1/2" Wrench
- Polyurethane sealant

Installing casters on tables with epoxy resin tops will void the Epoxy warranty.

Part Identifier Key

Part #	Description	Qty.	
0408231	#10 x 3/4" Square pan screws DO NOT Use on EPOXY tops!!	10 (Included in Hardware Pack located in leg box) DO NOT Use on EPOXY tops!!	

Caster Hardware will be included in Leg box: Installing casters on tables with epoxy resin tops voids the warranty.

3" Heavy Duty Caster Hardware Pack (04066968) Used only with 2" adj. legs (-ALR)

Part #	Description	Qty.	
04067460	1/4" Star washers	4 per set	
04067064	M6 1x18 screws <i>(Used in leg insert to prevent bending of the leg insert)</i>	4 per set (Included in Hardware Pack located in leg box as standard. Discard if casters are not installed.)	

3" Heavy Duty Caster Hardware Pack (0402020) Used only with 1.5" adj. legs (-ADJ)

Part #	Description	Qty.	
04067460	1/4" Star washers	4 per set	
0401259	M6 1x14 screws <i>(Used in leg insert to prevent bending of the leg insert)</i>	4 per set (Included in Hardware Pack located in leg box as standard. Discard if casters are not installed.)	

TORO Leg Options

